

Operator protection

Terminal boxes have a high short-circuit strength (terminals) and are highly short-circuit-proof (shatterproof).

In the event of a fault, the internal pressure is vented in one direction only. Injuries due to flying debris are prevented.

These properties have been verified in a neutral test laboratory in numerous internal fault tests on an infinite bus.

Electrical and mechanical design

Ample dimensions of the terminal boxes make for simple and safe connection of the supply cables. For the connection, either cable lugs (standard) or terminal clamps (special) are provided. Compoundfilled cable entries are available on request.

Terminal boxes meet the requirements of degree of protection IP54 to IEC 60529 and protection Ex eII EN 60079-7. All terminal boxes are designed for outdoor installation.

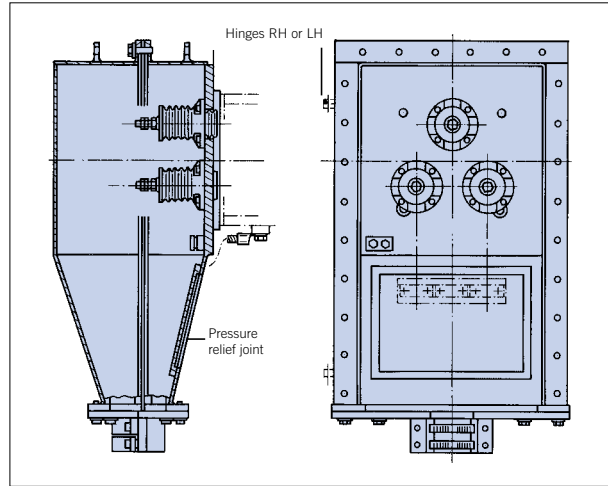

Terminal Box for 10 kV and for fault levels 330 or 800 MVA. Relief joint at the rear



Standard 6 kV terminal box with opened relief joint

1/0864



Terminal box with 6 kV cast-resin bushings

1/0866

In order to ensure the highest possible degree of safety, terminal boxes are made of non-splintering material. In addition, cast-resin bushings to DIN 46264 are used, which have a high bending and torsional strength. Pressure relief joints are arranged in such a way that an internal pressure is released either upwards or towards the machine.

Depending on the supply system, tested terminal boxes for the following fault capacities are available:

200/350/400 MVA up to 6.6 kV or 330/800 MVA up to 11 kV



Different terminal box designs

Min. conductor cross-section

In order to ensure our safety concept, the following minimum conductor cross-sections must be observed:

System fault level	Min. cond. cross-section Cu in mm ² at U _N =	
	6kV	10kV
MVA		
<200	70	70
>200-250	95	70
>250-350	150	95
>350-500	185	150
>500-800	-	185

On request, terminal plates can be provided for cable connectors IP66 for up to 11 kV and up to 400 A.